



## SC-222

Cinema Loudspeaker System



### Features

- Two-way, bi-amplified screen channel system
- HF-75C provides 90° horizontal by +20° to -35° vertical coverage
- LF-2215 is constructed of MDF and features single woofer chambers
- Low-distortion waveguide provides highly articulate dialogue
- Shallow depth (20") facilitates installation behind the screen

Developed specifically for the unique requirements of professional motion picture playback, the SC-222 extends QSC's commitment to the cinema market. As a member of the DCS Digital Cinema Speaker Series, the SC-222 is a bi-amplified, 2-way screen channel loudspeaker system comprised of two main units—the HF-75C high-frequency system and the LF-2215 low-frequency system.

The HF-75C high-frequency system features a 3" (75mm) titanium diaphragm compression driver mounted on a custom designed high-frequency cinema horn with an adjustable pan and tilt bracket. The HF-75C includes a driver protection and equalization network. DC blocking capacitors protect against DC or low-frequency signals that would likely destroy an unprotected driver. Power limiter circuitry protects the driver from overpowering and a response correction filter smooths the frequency response of

the horn/driver combination. The driver and equalization network provides for more reliable operation, ensuring the show will go on. LF-2215 dual 15" (381 mm) low-frequency enclosure is designed specifically to address the extended low-frequency response required for cinema applications.

LF-2215 covers the frequency range from 37 Hz to 1000 Hz, depending upon the high-frequency system requirements. Close Coupled Woofers (CCW), with their tight spacing between woofers, improves coupling and keeps coverage angles wide over a greater frequency range than more widely spaced designs.

The SC-222 is designed for ease of installation. The HF-75C components come pre-assembled to reduce field assembly time. Three bolts are all that are required to secure the HF-75C to the top of the LF-2215 enclosure.



# SC-222 Details

Specifications	SC-222	
Nominal Coverage	90° horizontal x +20 to -35° vertical	
Frequency Range	37 Hz – 16 kHz (-6 dB)	
Crossover Frequency	700 Hz, 24 dB per octave	
	LF-2215	HF-75C
Impedance	4Ω	8Ω
Sensitivity 1 watt/1 meter, half space	98 dB	108 dB
Maximum Input Power <sup>1</sup>		
8 hours of 6 dB crest factor IEC 268 noise spectrum	600 W RMS	40 W RMS
2 hours of 6 dB crest factor pink noise, 50 Hz – 20 kHz, AES method	800 W RMS	75 W RMS
Recommended Amplifier Power	1200 W RMS maximum	100 W RMS maximum
Recommended Processing	Subsonic filter below 30 Hz, > 18 dB per octave	4th order LR crossover at 700 Hz via QSC processor
Connectors	Barrier strip screw terminals accept up to #10 AWG stranded wire	Barrier strip screw terminals accept up to #10 AWG stranded wire
Transducers	Two 15" (381mm) high efficiency, extended bass woofers featuring 3" copper voice coils	1.5" (38mm) exit, 3" titanium diaphragm compression driver
Enclosure	Quasi B4 alignment, ported enclosure with fully flared ports, symmetrical port design, constructed of MDF and heavily braced. Features vandal resistant woofer mounting bolts	Tilt/Pan Bracket ±10° vertical tilt ±10° horizontal pan
Dimensions (HWD)	35.75" x 30" x 20.3" (9080 mm x 762 mm x 516 mm)	16" x 30" x 20" (406 mm x 762 mm x 508 mm)
Weight – Net	172 lb (78 kg)	40 lb (18.4 kg)
System Weight	212 lb (96.4 kg)	
Baffle Cut-Out	53"x32"	

1) Maximum input power tested in accordance with IEC 60268-5 recommendations, 30 Hz to 300 kHz band limiting.

Preliminary Specifications subject to change without notice.

# SC-222 Technical Drawing

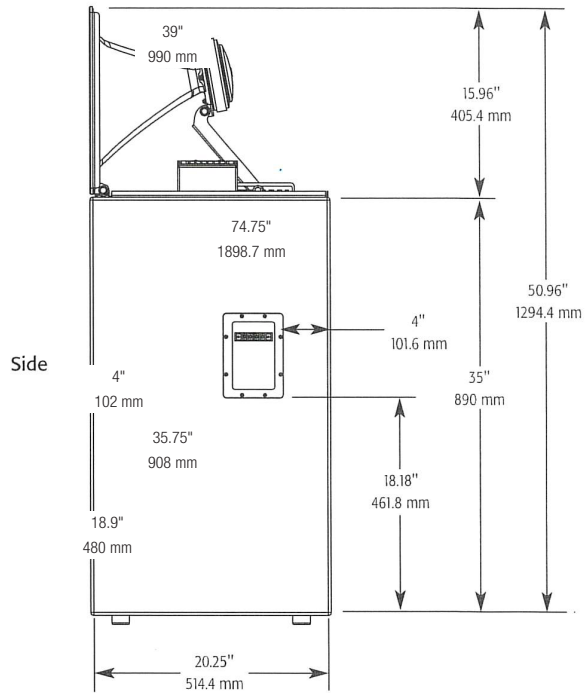
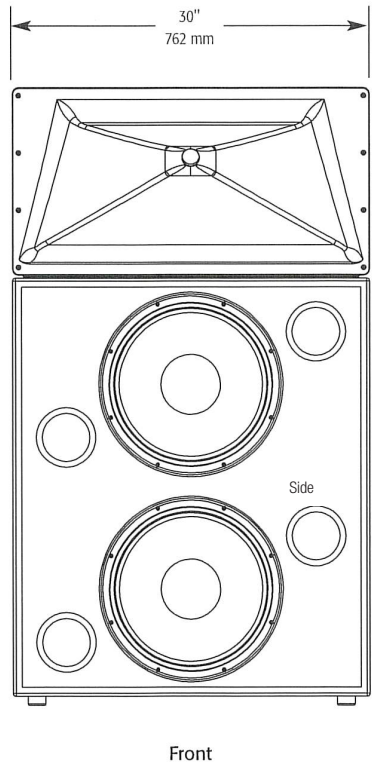
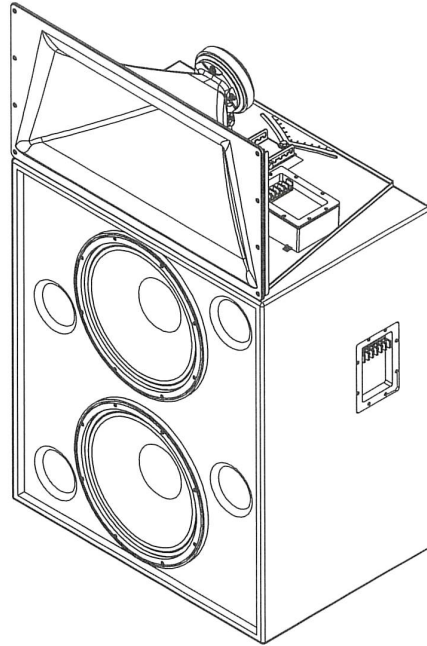
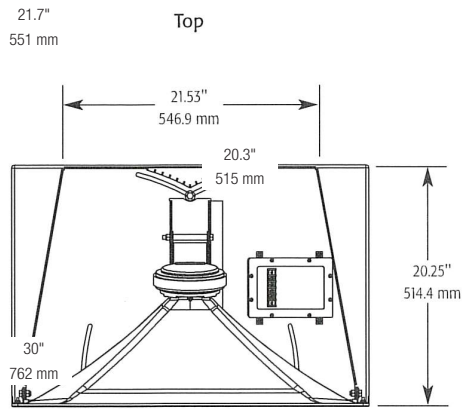

Specifications subject to change without notice.



1675 MacArthur Boulevard • Costa Mesa, CA 92626 • Ph: +1.800.854.4079 or +1.714.957.7100 • Fax: +1.714.754.6174



please recycle

©2020 QSC, LLC. All rights reserved. QSC and the QSC logo are registered trademarks of QSC, LLC in the U.S. Patent and Trademark office and other countries.

SC-222 Spec Sheet 03/31/2020



SOUND ASSOCIATES  
PROJECTION | SOUND | CINEMA | DIGITAL