



## SR-1290 Cinema Surround Loudspeaker

### Features

- High Performance for large cinemas
- 12" (305 mm) woofer with 2.5" (63 mm) voice coil
- 1.75" voice coil (44 mm) coaxially-mounted high frequency driver
- Pre-installed mounting hardware with multiple suspension options
- Very high-power handling meets the demands of object-based immersive audio formats
- Low impedance rating enables it to draw more power from amplifiers, allowing use of lower powered, less costly amplifiers.



New object-based cinema sound formats require surround loudspeakers capable of higher output and more flexible mounting options. The SR-1290 addresses these requirements with a high-power coaxial LF/HF driver and enclosure design. The result is a surround loudspeaker with high-power handling, excellent sensitivity, and extended bass response in a uniquely compact enclosure.

The SR-1290 Cinema Surround Loudspeaker features a high-power, long-throw 12" (305 mm) low-frequency transducer with a coaxially-mounted 1.75" (44 mm) titanium diaphragm compression driver. The coaxial alignment of the drivers occupies less baffle area compared to traditional over-under driver designs, reducing the size of the cabinet while maximizing output capability. Coaxial alignment also creates a "point source" radiation characteristic, so all frequencies are perfectly aligned through the crossover region, resulting in better sound quality. Since the coaxial driver inherently produces a conical dispersion pattern, the enclosure can be rotated without any effect on the coverage pattern.

The loudspeaker's 4 ohm impedance rating allows it to draw more power from the amplifier compared to an 8 ohm loudspeaker. For object-based audio formats where each surround loudspeaker requires

its own separate channel, this means more power will be delivered to each loudspeaker, allowing them to produce maximum output from lower-powered, less expensive multi-channel amplifiers. The 400 watt continuous power rating and sophisticated crossover with protection circuitry provides absolute reliability.

The SR-1290 is designed for safe and secure overhead mounting. The cabinet is constructed of 15-mm Baltic birch plywood with internal bracing for superior structural integrity. The rear panel of the cabinet is fitted with six threaded insert mounting points that accommodate the standard bolt pattern for most third-party bracket manufacturers. A set of four mounting points centered on the cabinet's rear panel allows the use of a multiple angle aiming bracket for ceiling mount applications where the loudspeaker needs to be aimed directly downward. Pre-installed speaker-side hardware allows fast single-installer wall mounting, and brackets support down-angles of either 15° (standard) or 23° (optional). A traditional U-bracket (YM-400) is also available. The compact black enclosure features the same styling as our other SR family surround loudspeakers, so you can easily combine different models (for example, SR-1290 in front-screen locations and SR-1030 on side and rear walls) and maintain a consistent aesthetic appearance.

# SR-1290 Details

System Details	SR-1290
Rated Coverage Angle (-6 dB)	90° conical (averaged from 1 kHz to 8 kHz)
Frequency Range (-10dB) <sup>1</sup>	50 Hz to 20 kHz
Rated Noise Power <sup>2</sup>	400 W
Sensitivity <sup>3</sup>	96 dB
Maximum Rated SPL <sup>4</sup>	122 dB @ 1m, continuous 128 dB @ 1m, peak
Rated Impedance	4Ω nominal
Maximum Recommended Amplifier Power	800 Watts
Transducer	12" (305 mm) LF driver with coaxially-mounted 1.75" HF driver
Enclosure Details	
Input Connector	4-position barrier strip, accepts up to #10 AWG stranded wire
Enclosure Material	15 mm Baltic birch plywood, non-reflective black vinyl
Grille	Black Cloth
Dimensions (HxWxD)	20.1" x 15.75" x 12.1" (511 mm x 400 mm x 308 mm)
Net Weight	36.5 lb (16.5 kg)
Optional Accessories	QM-SW, QM-BW, YM-400

As part of QSC's ongoing commitment to product development, specifications are subject to change without notice.

<sup>1</sup> Free-field, -10 dB from on-axis sensitivity

<sup>2</sup> AES2-1984 noise signal for 2 Hrs

<sup>3</sup> On-Axis, free-field sensitivity, 2.0V, 1 m

<sup>4</sup> Calculated from rated noise voltage and sensitivity

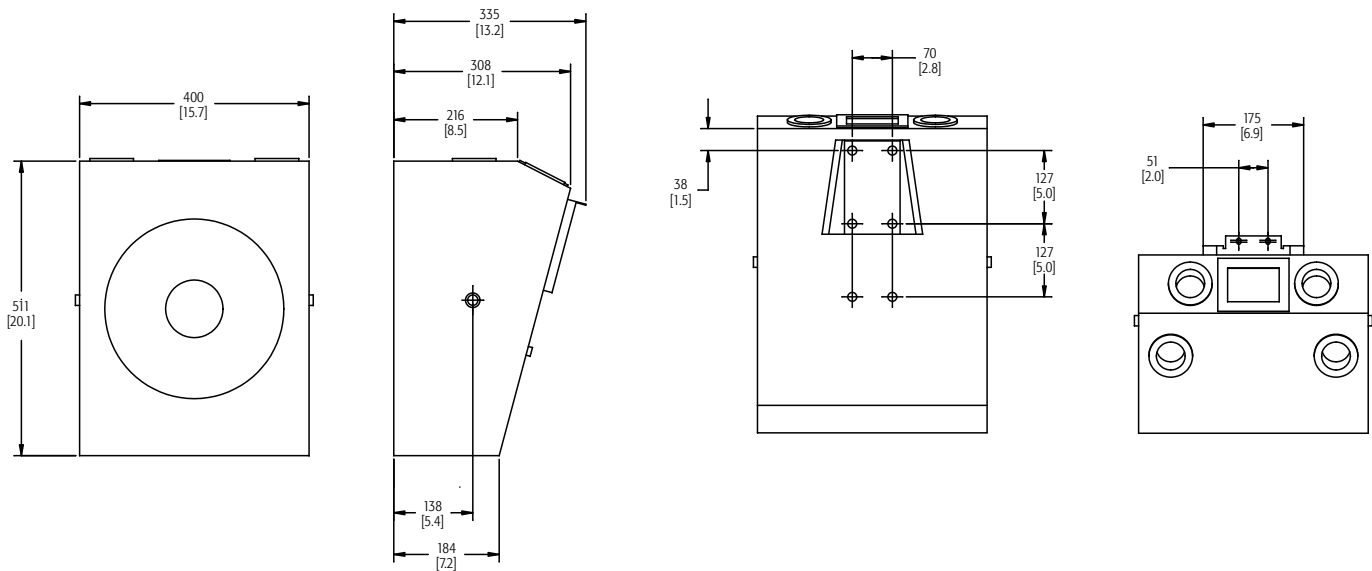

Specifications subject to change without notice.



1675 MacArthur Boulevard • Costa Mesa, CA 92626 • Ph: 800/854-4079 or 714/957-7100 • Fax: 714/754-6174



please recycle

© 2014 QSC and the QSC logo are registered trademarks of QSC Audio Products, LLC in the U.S. Patent and Trademark office and other countries. All other trademarks are the property of their respective owners. Patents may apply or be pending.